

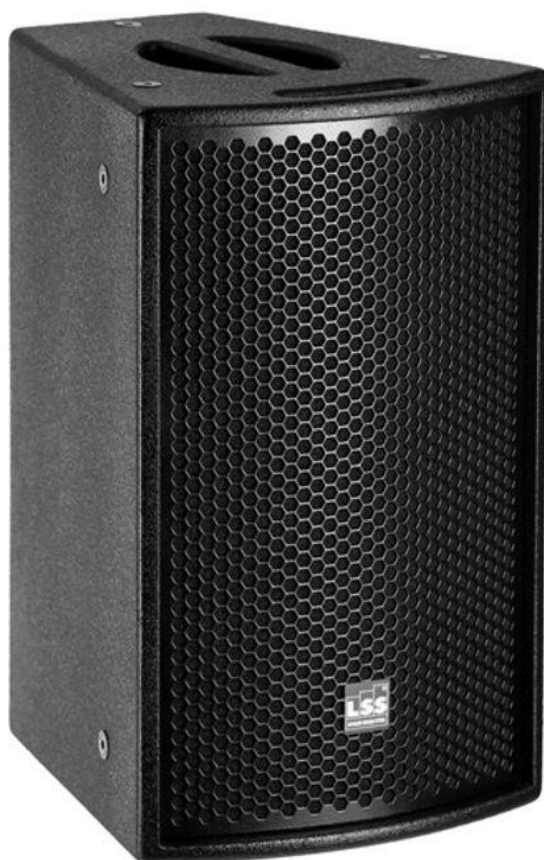

PROFESSIONAL AUDIO SYSTEM

SP425A



OPERATING MANUAL

Ver. SP425A-EN-1.1

LSS Advanced Speaker Systems

Via On. Longo 53-89024 Polistena (RC) ITALY Tel (39) 966 9321299 – Fax (39) 966 933007 Email: info@lss.it - Internet: www.lss.it

NOTICE:

LSS products are manufactured for use according to proper procedures by a qualified operator and only for the purposes described in this manual. The following conventions are used to indicate and classify precautions in this manual. Always heed the information provided with them. Failure to heed precautions can result in injury to people or damage to property.

© LSS, 2016

All rights reserved. No part of this publication may be reproduced, stored in a retrieval system, or transmitted, in any form, or by any means, mechanical, electronic, photocopying, recording, or otherwise, without the prior written permission of LSS.

No patent liability is assumed with respect to the use of the information contained herein. Moreover, because LSS is constantly striving to improve its high-quality products, the information contained in this manual is subject to change without notice. Every precaution has been taken in the preparation of this manual. Nevertheless, LSS assumes no responsibility for errors or omissions. Neither is any liability assumed for damages resulting from the use of the information contained in this publication.

SUMMARY

INTRODUCTION	4
SAFETY AND WARNING.....	5
APPLICATION.....	6
PHYSICAL DESCRIPTION.....	6
TECHNICAL SPECIFICATIONS	7
INSTALLATION AND WIRING	8
WEEE DIRECTIVE	11
TROUBLESHOOTING	12
DIMENSIONS.....	13
NOTES	14

INTRODUCTION

Congratulation on the purchase of your new LSS loudspeaker. Quality innovation and versatility, this is a summary of the new system developed by LSS for professional sound users. LSS produces professional audio products – the result of exceptional engineering and meticulous craftsmanship. This manual is intended for use with LSS loudspeaker. This includes: safety precautions; installation, set-up and operating instruction. Please read this manual plus any accompanying manual and follow all relevant precautions and instructions. This should allow you to obtain the maximum performance from your new loudspeaker. Where there are conflicts or overlaps, the information in any accompanying manual supersedes the information in this manual.

SAFETY AND WARNING

IMPORTANT! SAFETY WARNING!

In the interest of their own and others' safety and to prevent voiding the warranty, we recommend a careful reading of this section before using the product.

- This product was designed and manufactured to be used as a speaker system in the context of a typical sound reinforcement system.

The use for any purpose other than these is not provided by the manufacturer and is therefore under the direct responsibility of the user / installer.

- This device complies with class I (must be connected to the outlet with a protective earthing connection).



WARNING

RISK OF ELECTRIC SHOCK
DO NOT OPEN

TO REDUCE THE RISK OF ELECTRIC SHOCK
DO NOT REMOVE COVER (OR BACK)
NO USER SERVICEABLE PARTS INSIDE
REFER SERVICING TO QUALIFIED SERVICE PERSONNEL
TO REDUCE THE RISK OF FIRE OR ELECTRIC SHOCK
DO NOT EXPOSE THIS EQUIPMENT TO RAIN OR MOISTURE

TO AVOID THE RISK OF FIRE AND / OR ELECTRIC SHOCK*:

- Do not expose this system to rain or moisture. Do not expose the apparatus to dripping or splashing water. Do not place objects filled with liquids, such as drinks, on the apparatus.

- Before connecting the system, be sure the mains voltage corresponds to that stated on the product.

- Connect this appliance to a power outlet with earth contact, according to national security force, via a power cable of adequate section ends with a plug or connector that meets the applicable safety regulations.

- The unit is connected to the network even when the power switch is in position '0' (OFF). Before any maintenance, disconnect the power cable from the outlet.

*Risk of electric shock only for self-powered system.

IMPORTANT! SAFETY PRECAUTIONS!

Read This First.

Read and heed all warnings and safety instructions in this Manual before using the product.

Failure to follow all precautions can result in equipment damage and / or personal injury.

1. Read these instructions.
2. Keep these instructions
3. Heed all warnings and follow all instructions.
4. Use only attachments/accessories specified by the manufacturer.
5. Use only with the cart, stand, tripod, bracket, or table specified by the manufacturer, or sold with the apparatus. When a cart is used, use caution when moving the cart/apparatus combination to avoid injury from tip-over.
6. Refer all servicing to qualified service personnel. Servicing is required when the apparatus has been damaged in any way, such as power-supply cord or plug is damaged, liquid has been spilled or objects have fallen into the apparatus, the apparatus has been exposed to rain or moisture, does not operate normally, or has been dropped.
7. LSS loudspeakers can produce sound levels capable of causing permanent hearing damage from prolonged exposure. The higher the sound level, the less exposure needed to cause such damage

CAUTION: This product is energized as long as it is connected to the AC.

CAUTION: Allow at least six inches of free space all around the amplifier for sufficient ventilation.

APPLICATION

LSS's SP425A is a 2-way loudspeaker system that provides high output, low distortion sound reinforcement for the entire range of pro audio applications.

The 250 mm (10") low frequency cone and 44 mm (1.75") voice coil high frequency compression driver provides higher output and lower distortion plus enhanced power handling capabilities for better performance in both portable and permanently installed applications. The SP425A powering mode is active with digital amplifier.

The SP425 was designed for distributed systems, the 13° per side trapezoidal angles match the 90° horizontal coverage pattern allowing the creation of tight packed clusters. The pole mount cup and balance-optimized handles allow for quick and easy load-in for portable use. Its high output capabilities let it act as a main system for smaller concert or portable A/V events or even provide front or side fill for concert touring applications. The comprehensive system mounting points allow safe suspension in permanent installations.

PHYSICAL DESCRIPTION

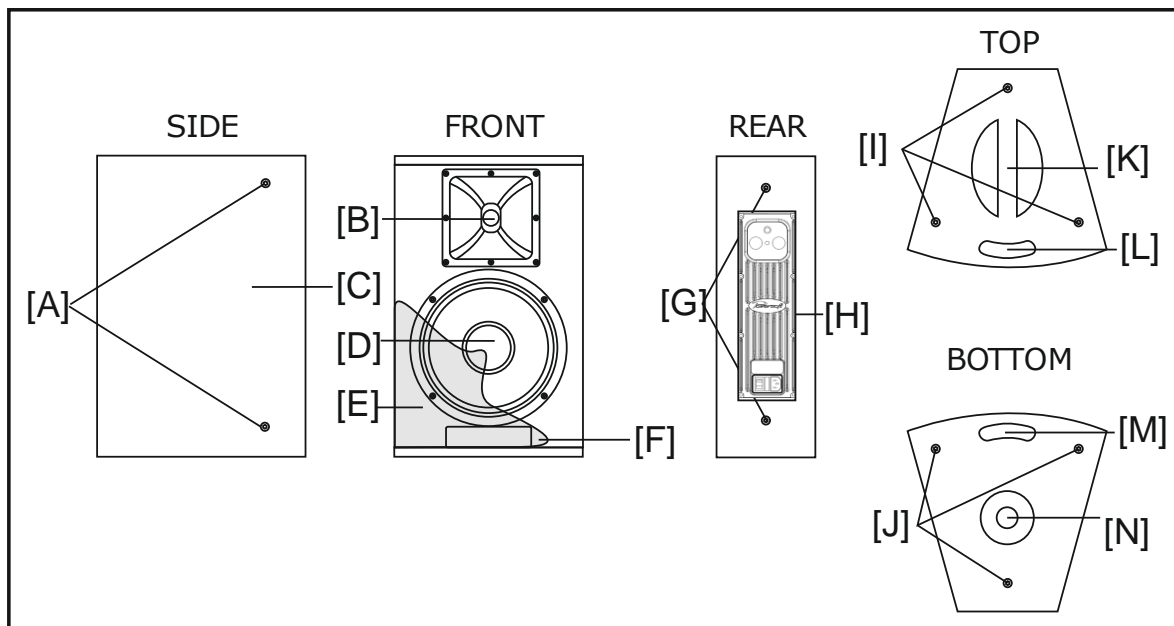

- [A] Side Fixing Points
- [B] HF Driver
- [C] Enclosure Cabinet
- [D] Woofer
- [E] Steel Protection Grid
- [F] Reflex
- [G] Rear Fixing Points

- [H] Connection Panel
- [I] Top Fixing Points
- [J] Bottom Fixing Points
- [K] Handle
- [L] Handle
- [M] Handle
- [N] Pole Mount Cup

Materials and construction meet the highest professional standards to ensure maximum reliability.

TECHNICAL SPECIFICATIONS

PHYSICAL	Dimensions mm (±1 mm) [Inches]	Height 510 [20.08"]
		Front Width 320 [12.60"]
		Rear Width 160 [6.30"]
		Depth 365 [14.37"]
		Trapezoidal Angles 13°
	Weight Kilograms	Net Weight 21 Shipping Weight 24
SYSTEM PERFORMANCE	Frequency Response	±5 dB 65 Hz ~ 18 KHz
		-10 dB 45 Hz
	Sensitivity (1 Watt @ 1 m)	Full Range 96 dB
		LF 96 dB
		HF 103 dB
	Max SPL Calculated (Power EIAJ) [PEAK]	123 dB [126 dB]
	Nominal Input Impedance (Ω)	Full Range 4Ω
		LF 4 Ω
		HF 16 Ω
	Power Handling (EIAJ) [PEAK]	540 W [1080 W]
Nominal Dispersion (@ -6 dB)	Horizontal 90°	
	Vertical 40°	
MECHANICAL	Enclosure material	Birch Plywood of 15 mm [0.59 inches]
	Finish	Texture polyurethanic black paint
	Suspension	12 Point Mounting Suspension
	Grille	Powder coated perforated steel with anti-dust foam
	Connectors	XLR IN & OUT, AC Power: 240V, VDE Connector
	Optional Accessories	Fly Clip with Ring, Speaker Soft Bag

INSTALLATION AND WIRING

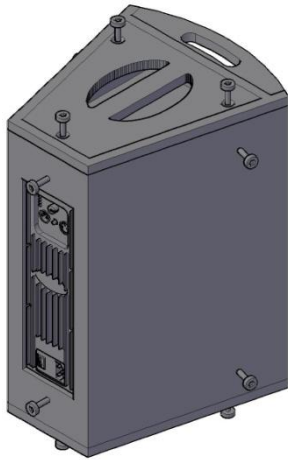

SP425A speaker can be mounted to the wall, on a pole or suspended through the suspension points.

For installation on a pole, use the pole mount plate in the bottom of the case, speaker can be mounted on a tripod or on another speaker (sub).

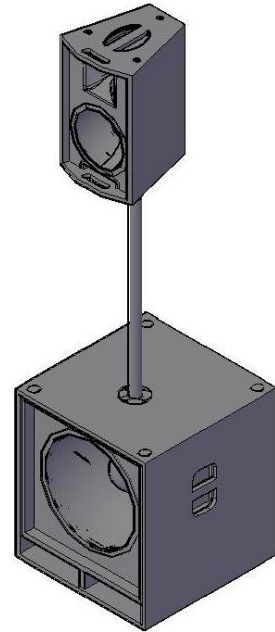
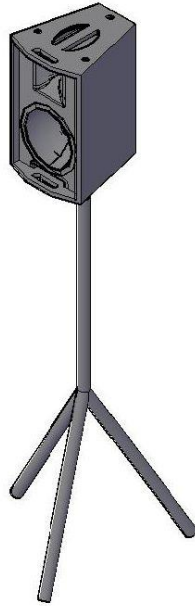

For suspended installation, there are six brackets inside the case: three in the top, three in the bottom. Each bracket is secured to two adjacent internal side of speaker using two M10 screwbolts.

If needed, replace the screwbolts with eyebolts.

More detailed:

- One bracket is connected between top and left side of case.
- One bracket is connected between top and right side of case.
- One bracket is connected between top and rear side of case.
- One bracket is connected between bottom and left side of case.
- One bracket is connected between bottom and right side of case.
- One bracket is connected between bottom and rear side of case.

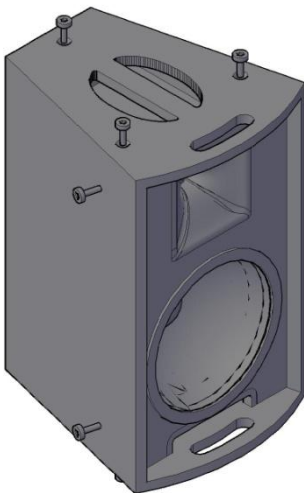

When installation is in suspended mode, use the upper or lower brackets. Unscrew one of the two screws hold a single bracket, the second screw must be screwed only after the first one has been tightened to avoid the bracket moves.

It is possible to install a maximum of three speakers in cascade using eyebolts.

Use plugs suitable to support the weight of the entire apparatus.

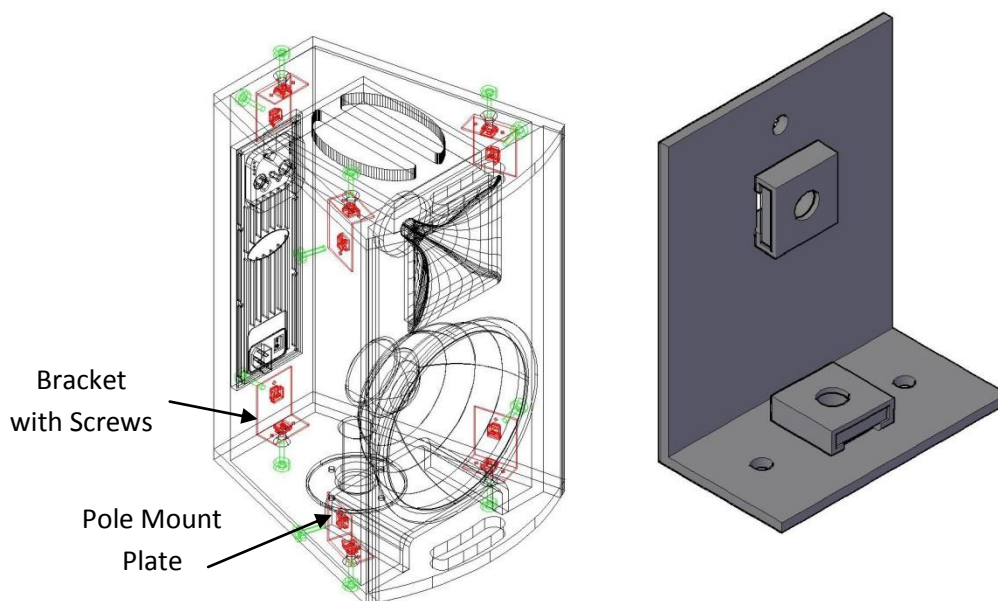

Choose a safe mounting location, so as to prevent the cables can be stepped on or create tripping hazards.

Connection are made via 3-pin XLR connector.

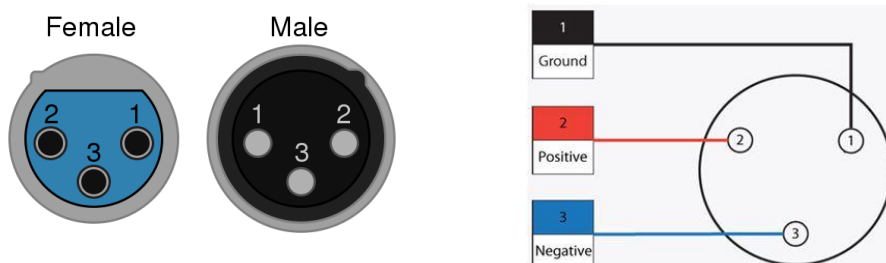

Before making connection between mixer and active speaker, make sure all the switches of the speakers are turned off and the mixer volume is turned down. To avoid a sudden signal, making connection, then turn on the mixer first and then the speakers. Turn on the amplifier by the power switch to position 1 (on).

When the system start, it will turn on 3 LEDs, after a few seconds will stay on only two or three if the input signal is present, when the amplifier turn on, start with the preset the previously loaded.

You can now use the system.

If necessary, adjust the volume by adjusting the potentiometer.

If you want to change the preset, follow the instruction below.



LOADING A PRESET

The active preset is indicated by the corresponding LED. It is possible to change presets by pressing the center pushbutton **P**.

- P1** – preset 1 (green): indicates the factory presets **SMOOTH**.
- P2** – preset 2 (green): indicates the factory presets **VOCAL**.
- P3** – preset 3 (green): indicates the factory presets **LOUD**.
- P4** – preset 4 (green): indicates the factory presets **FLAT**.

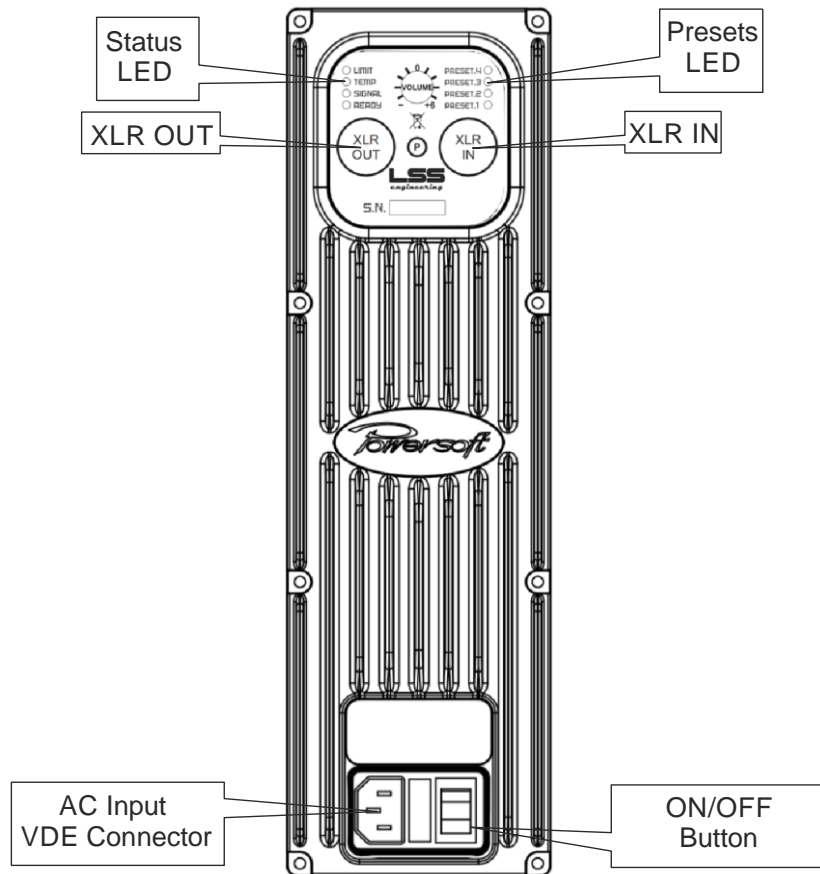

WEEE DIRECTIVE

WEEE Directive

Warning!

The product is marked with this symbol which indicates not to discard electrical and electronic equipment via the normal procedure for disposal of household waste. For these products there is a diverse collection system in accordance with legislation that requires proper treatment, recovery and recycling of used products. For more information please contact the appropriate local authority.

The black bar underneath indicates that the product was placed on the market after 13 August 2005.

INFORMATION FOR PROPER DISPOSAL

For home users

In the European Union

Warning: To dispose of this equipment, do not use the ordinary dust bin!

The electrical and electronic equipment must be treated separately and in accordance with legislation that requires proper treatment, recovery and recycling of used products. Following the implementation by member states, private households within the EU can give free electrical and electronic equipment to designated collection facilities*.

In some countries (*), your local retailer may withdraw the old product for free if you purchase a new one of similar type.

* For more information please contact the appropriate local authority.

In countries outside the EU: please contact your local authorities and ask for the correct method of disposal.

In Switzerland: Used electrical or electronic equipment can be returned free of charge to the dealer, even if you do not purchase a new product.

Further collection facilities are listed on the homepage or www.swico.ch.
www.sens.ch.

For professional users

In the European Union

Warning: If the product is used for business purposes, the following steps to delete it:

contact your LSS dealer for information about the product recall.

Might be charged for the costs of collection and recycling. Small products (and amounts) might be taken back by your local collection facilities.

In Spain: contact the established collection system or the local authority for collection of used products.

In countries outside the EU: please contact your local authorities and ask for the correct method of disposal.



TROUBLESHOOTING

Problem	Possible cause (s)	Action
1. No Sound	Amplifier	Connect a known working test speaker to the amplifier outputs. If there is no sound, check that all the electronics are on, the signal routing is correct, the source is active, the volume is turned up, and so on. Correct/repair/replace as necessary. If there is sound, the problem is in the wiring. Check the amplifier is On, the green LED is On and SIGNAL LED blink. Then control Volume Knobs is open.
	Wiring	Verify that you have connected the correct XLR connector to the amplifier. Play something at low level through the amplifier (for example, from a CD player or tuner). If the sound level has gone or is very weak, the line has a short in it (possibly a severe scrape, pinch, or staple puncture). If the sound level is normal, the wire is open (possibly a cut wire or a missed connection).
2. Poor Low Frequency Response	Speakers wired out-of-polarity	When two speakers are connected out of polarity observe the wire markings on your XLR connector. Verify that pin 2 is + terminal and pin 1 is - negative.
3. Intermittent output such as crackling or distortion	Faulty Connection	Check all connections to ensure they are all clean and tight. If the problem persists, it may be in the amplifier or wiring. See Problem 1 above.
4. Constant noise such as buzzing, hissing, humming	Defective amplifier or other electronic Devices	If the noise is present but no program material is playing, the likely cause is the signal chain in the electronics. Evaluate each component as necessary to isolate the problem.
	Poor system grounding or ground loop	Check and correct the system grounding, as required.
If these suggestions do not solve your problem, contact your nearest LSS dealer or LSS distributor.		

DIMENSIONS

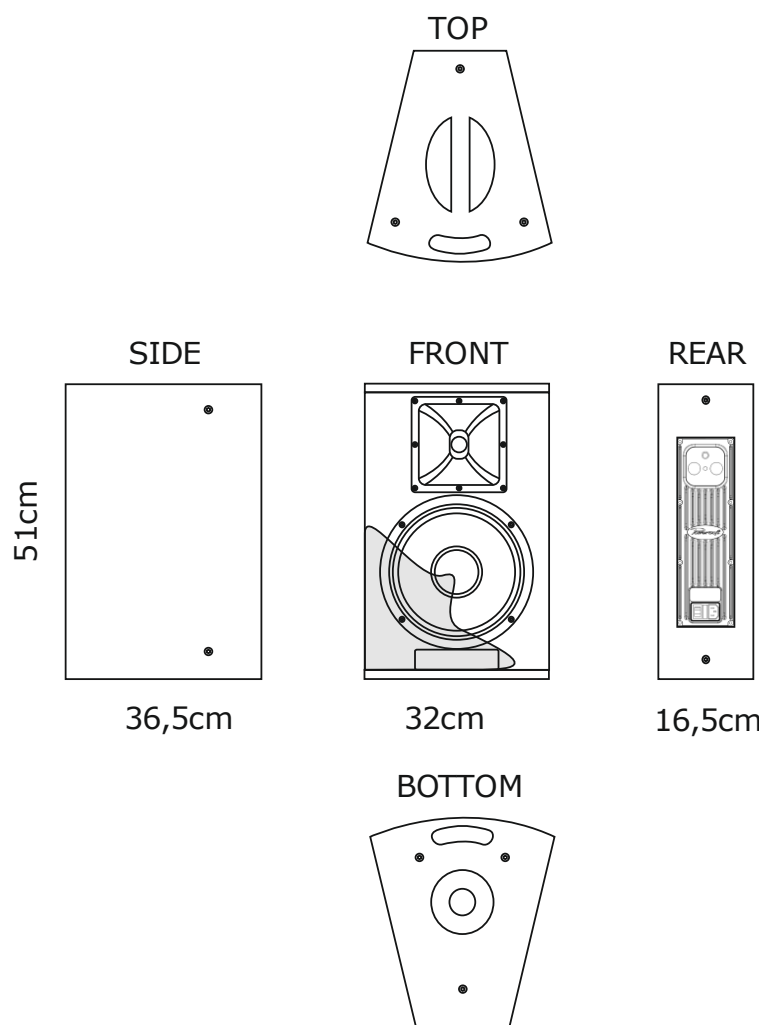

NOTES



CONTACT INFORMATION:

LSS Advanced Speaker Systems

Via On. Longo 53
89024 Polistena (RC) ITALY
Tel (39) 966 9321299 – Fax (39) 966 933007
Email: info@lss.it - Internet: www.lss.it